

THIS SHEET INCLUDES FITTING INSTRUCTIONS FOR THE FOLLOWING PARTS:

Secondary Alternator Cover Part No. EC-CBR1000-2017-1-GBR / Secondary Clutch Cover Part No. EC-CBR1000-2017-2-GBR /
Secondary Pulse Cover Part No. EC-CBR1000-2017-3-GBR
Bullet Frame Race Slider Set - RACE - Part No. FS-CBR1000-2008-R /
Paddock Stand / Bobbin Set Part No. BA12-8-GBR-SET / Lower Chain Guard Part No. CGA10-GBR



SECONDARY ALTERNATOR COVER
PART NO. EC-CBR1000-2017-1-GBR

1. Remove original fairing panel and plastic cover that is fitted over the original alternator cover.
2. Remove 4 existing bolts from the stock Alternator cover, shown as position Bolt 1, 2, 3 & 4.
3. Place the Secondary Alternator Cover over the stock cover.
4. Assemble 4 replacement bolts (M6X35HHF) loosely in the correct position as shown.
5. Tighten bolts to a Torque of 10Nm as per Manufacturer's recommendations. **DO NOT OVERTIGHTEN.**
6. Replace original plastic cover and fairing.

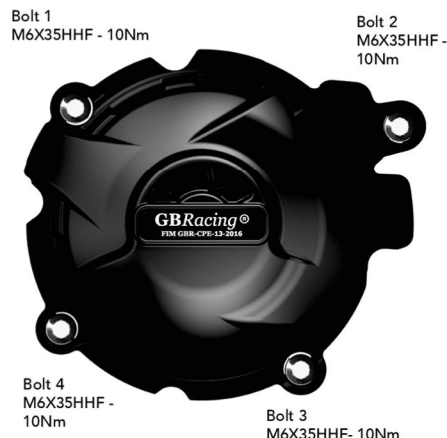
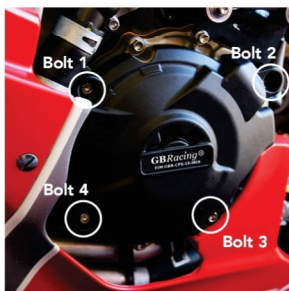

SECONDARY CLUTCH COVER
PART NO. EC-CBR1000-2017-2-GBR

1. Remove fairing.
2. Remove 3 existing bolts from the stock Clutch cover, shown as position Bolt 1, 2 & 3.
3. Place the Secondary Clutch Cover over the stock cover.
4. Loosely assemble bolt 3 first (2-3 turns), then bolts 1 & 2, with the replacement bolts supplied (M6X35HHF).
5. Tighten bolts to a Torque of 10Nm as per Manufacturer's recommendations. **DO NOT OVERTIGHTEN.**
6. Replace fairing.

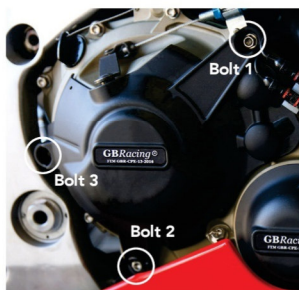

SECONDARY PULSE COVER
PART NO. EC-CBR1000-2017-3-GBR

1. Remove offside fairing infill panel.
2. Remove 4 existing bolts from the stock Pulse cover, shown as position Bolt 1, 2, 3 & 4. **Note:** Bolt 1 has a sealing washer that needs retaining for re-use later.
3. Place the supplied M6WCU copper washer over 1 off M6X35HHF (Hex Head Flanged) bolt and then mount this bolt through Bolt Position 1 of the moulded alternator cover. Place the original OEM washer back over the threaded end of this bolt. (As illustrated in Fig 1).
4. Place the Secondary Pulse Cover over the OEM stock cover.
5. Assemble the remaining 3 replacement bolts loosely in the correct position as shown.
6. Tighten bolts to a Torque of 10Nm as per Manufacturer's recommendations.
7. Refit offside fairing infill panel.

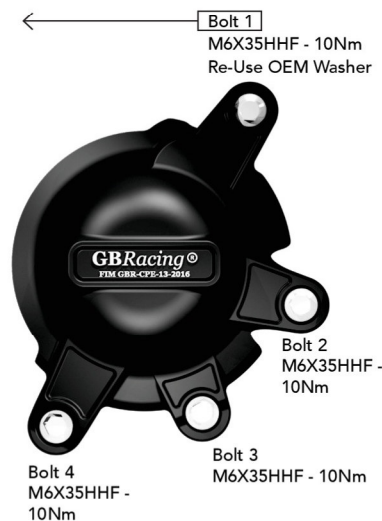

BULLET FRAME SLIDER - LEFT HAND SIDE - RACE
PART NO. FS-CBR1000-2008-LHS-R

1. Remove left hand side fairing panel from bike.
2. Remove lower engine / frame mounting bolt.
3. Assemble bolt through the aluminium bush into correct position.
Please note: We recommend copperslip to be used on the thread of our replacement bolt before it is inserted
4. Tighten to 64NM torque.
5. Slide bullet moulding onto aluminium bush.
6. Screw M6 bolt into front of bullet moulding hand tight.
7. Replace left hand side fairing panel.

PLEASE NOTE: These are only sold separately and are not available in our Bundles.
Bullet Frame Race Slider Set - RACE - Part No. FS-CBR1000-2008-R



BULLET FRAME SLIDER - RIGHT HAND SIDE - RACE
PART NO. FS-CBR1000-2008-RHS-R

1. Remove right hand side fairing panel from bike.
2. Remove lower engine / frame mounting bolt.
3. Assemble bolt through the aluminium bush into correct position.
Please note: We recommend copperslip to be used on the thread of our replacement bolt before it is inserted
4. Tighten to 64NM torque.
5. Slide bullet moulding onto aluminium bush.
6. Screw M6 bolt into front of bullet moulding hand tight.
7. Replace right hand side fairing panel.

PLEASE NOTE: These are only sold separately and are not available in our Bundles.
Bullet Frame Race Slider Set - RACE - Part No. FS-CBR1000-2008-R



PADDOCK STAND / BOBBIN SET
PART NO. BA12-8-GBR-SET

- 1 Assemble M8 x 40mm Bolt through the moulded bobbin.
- 2 Tighten bolts to swing arm boss, 8 Nm.
DO NOT OVERTIGHTEN



1 x Moulded Paddock Stand / Bobbin

LOWER CHAIN GUARD
PART NO. CGA10-GBR

- 1 Assemble 2 bolts and washers through the lower chain guard into the Black Anodised aluminium mounting block CGA10-2.
- 2 Position the assembly underneath the swing arm, closing the gap to the rear sprocket.
Note : There should be a 5mm minimum gap from the bike chain to the lower chain guard.
- 3 Mark off the chosen hole positions.
- 4 Drill & Tap the marked holes , M6 - (Drill 5mm Dia. for tapping)
- 5 Disassemble the Black Anodised block from the assembly, and mount the block to the underside of the swing arm using the remaining 2 bolts and washers.
- 6 Re-assemble the lower chain guard to the fixed bracket.



2 x Bolts & Washers
M6x20 - 10Nm